

(No Model.)

W. THOMPSON & J. A. GEORGE.

HAT POUNCING MACHINE AND LATHE.

No. 295,690.

Patented Mar. 25, 1884.

Fig. 1.

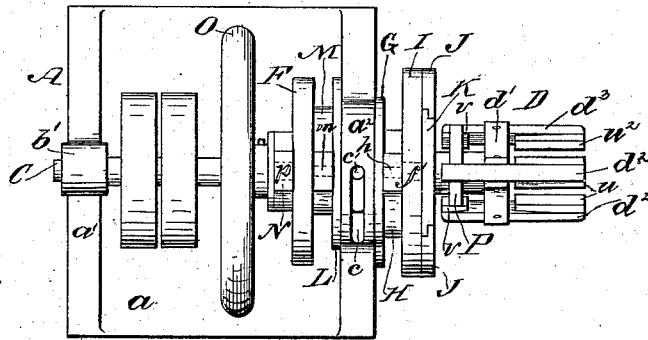

Fig. 8.

Fig. 7.

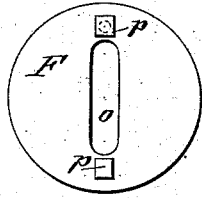

Fig. 2.

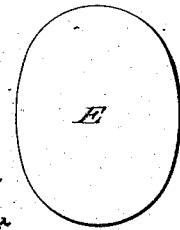
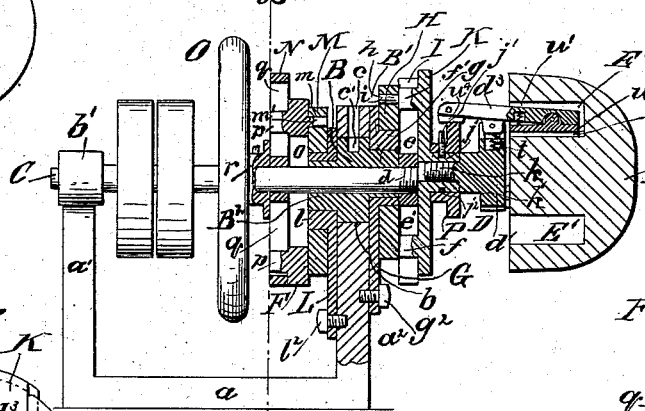

Fig. 3.

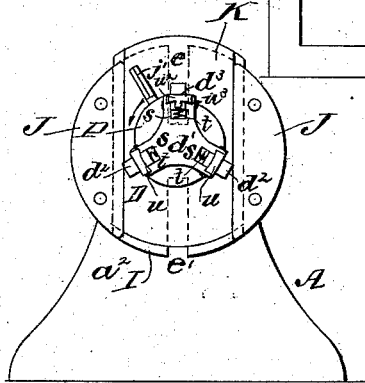

Fig. 4.

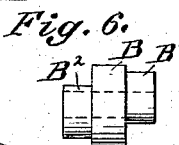
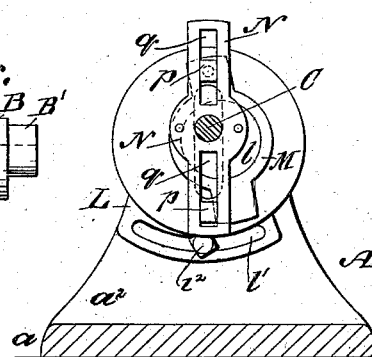
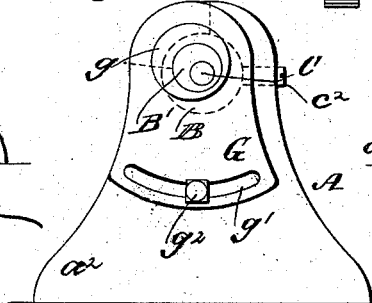

Fig. 5.



WITNESSES:

John R. Deemer  
C. Sedgwick

INVENTOR:

W. Thompson  
J. A. George

BY

Munn & Co  
ATTORNEYS.

# UNITED STATES PATENT OFFICE.

WILLET THOMPSON AND JOSEPH A. GEORGE, OF BROOKLYN, NEW YORK,  
ASSIGNORS TO THE BROOKLYN NEEDLE WORKS, OF SAME PLACE.

## HAT-POUNCING MACHINE AND LATHE.

SPECIFICATION forming part of Letters Patent No. 295,690, dated March 25, 1884.

Application filed January 22, 1884. (No model.)

*To all whom it may concern:*

Be it known that we, WILLET THOMPSON and JOSEPH A. GEORGE, of Brooklyn, in the county of Kings and State of New York, have  
5 invented a new and useful Improvement in Combined Hat-Pouncing Machines and Lathes, of which the following is a full, clear, and exact description.

This invention consists, principally, of a hat-  
10 pouncing machine provided with a special form of counter-balance, to prevent the swaying or lurching movement of the machine, usually caused by the irregular movement of the block, thus enabling the machine to be run at  
15 a high rate of speed, and in providing the machine with means for shifting the position of the "still-point," thus adapting the machine to be used also for turning hat-blocks and other  
irregular forms.

20 The invention consists, also, of a new form of chuck for holding the hat block or blocks to be turned, and also of the construction, arrangement, and combination of parts, all as hereinafter described and claimed.

25 Reference is to be had to the accompanying drawings, forming part of this specification, in which similar letters of reference indicate corresponding parts in all the figures.

Figure 1 is a plan view of our improved hat-  
30 pouncing machine and lathe. Fig. 2 is a sectional side elevation of the same, showing a hat-block held by the chuck. Fig. 3 is a front elevation of the machine. Fig. 4 is a transverse sectional elevation on the line  $xx$  of Fig.  
35 2. Fig. 5 is a front elevation of the machine, with the yoke H, plate I, face-plate K, and chuck D removed. Fig. 6 shows the shifting collar removed. Fig. 7 is a front elevation of the counterbalancing-plate removed, and Fig.  
40 8 is a front elevation of the hat-block E.

A represents the frame of the machine, which frame comprises the base  $a$  and uprights  $a'$   $a''$ .

In the circular opening  $b$ , made through the upright  $a''$ , is fitted the collar B. The main  
45 shaft C of the machine takes its bearing at its forward end in the collar B, and at its rear end in the journal  $b'$ , made in the upright  $a'$ . The collar B has formed integral with it, or has attached rigidly to it, the opposite eccen-  
50 trics  $B'$   $B''$ , which serve to impart, through

mechanism hereinafter described, the desired irregular rotary motion to the chuck D and hat-block E or other object attached thereto, and a like but opposite irregular motion also to the counterbalancing-disk F, and the collar B is adapted to be given a one-quarter turn,  
55 or thereabout, in the circular opening  $b$ , by passing a rod down through slot  $c$ , made in the upper edge of the upright  $a''$ , into orifice  $c'$ , for shifting the so-called "still-point"—the  
60 point where the surface of the block E runs true—from a position nearly over the shaft C, where it is most convenient to apply the sand-paper for pouncing a hat-body on the block  
65 E, to a position at the side of the shaft C, where it is most convenient to apply a cutting-tool for turning a block held in the chuck D.

Upon the eccentric  $B'$  is fitted the plate G, which is formed with the eccentric  $g$ , surround-  
70 ing the eccentric  $B'$ . The back of this plate G comes flat against the front surface of the upright  $a''$  of the frame of the machine, as shown clearly in Fig. 2, and the plate G is formed  
75 with the curved slot  $g'$ , through which the set-screw  $g''$  passes, for holding the plate G at any desired position. By loosening the set-screw  
80  $g''$  the plate G may be adjusted—turned backward or forward upon the eccentric  $B'$  for increasing or diminishing the irregular motion imparted to the chuck D and block E.

Upon the eccentric  $g$  of the plate G is fitted the yoke H, which has the orifice  $h$  formed in one end thereof.

The forward end of the main shaft C is screw-  
85 threaded, as shown at  $d$ , and upon this screw-threaded portion is screwed the plate I, which is formed with the slots  $e$   $e'$ , and turns at all times with the shaft C as a part of it.

To the front surface of the plate I are secured the flanged plates J J, between the adjacent  
90 edges of which the face-plate K is held. The plate K has formed upon its rear surface the block  $f$ , which fits in the slot  $e'$  of the plate or disk I, and the plate K is also furnished at the back with the block  $f'$ , which fits in the slot  $e$   
95 of the said plate I, and this block  $f'$  is formed with the pin  $i$ , which reaches past the rear surface of the plate I and enters the orifice  $h$ , made in the yoke H, as shown clearly in Fig. 2, so  
100 that since the plate I revolves with the shaft

C as a part of it, the yoke H and face-plate K, being connected together by the block  $f'$  and pin  $i$ , through the slot  $e$  of the plate I, will be caused to revolve with a positive motion by the plate I, and the yoke H, being placed upon the eccentric  $g$ , revolves thereon, and this eccentric thus imparts an irregular motion to the yoke H, and the yoke in turn imparts an irregular endwise motion to the face-plate K, the slots  $e e'$  and the flange-plates J J permitting such endwise movement. The chuck D is attached rigidly to the plate K by the screw-threaded shank  $k$  of the chuck, which is screwed into the internally-screw-threaded collar  $k'$ , formed upon the front surface of the plate K, so that the chuck D and block E, held thereon, are given a rotary irregular motion, precisely similar to the motion imparted to the plate K. The irregular rotary motion of the plate K, chuck D, and block E, when the machine is run at a high speed, tend to cause a swaying or lurching movement of the shaft C, and all of the other parts of the machine; but this lurching movement is prevented by the above-mentioned counterbalancing-plate F, which has an irregular rotary movement the reverse of that of the face-plate K. The irregular motion of the plate F, as above mentioned, is obtained from the eccentric  $B^2$ , formed upon the rear surface of the collar B, which eccentric is the opposite of the eccentric  $B'$ , and has fitted upon it the plate L, which is formed with the eccentric  $l$ , (the opposite of the eccentric  $g$  of plate G,) surrounding the eccentric  $B'$ . The back of the plate L comes flat against the rear surface of the upright  $a^2$  of the frame of the machine, and is formed with the curved slot  $l'$ , through which the set-screw  $l^2$  passes, for securing the plate L at any desired position. By loosening the set-screw  $l^2$ , the plate L may be adjusted for increasing or diminishing the irregular motion imparted to the counterbalancing-plate F.

Upon the eccentric  $l$  of plate L is fitted the yoke M, which has the orifice  $m$  formed in it, in which fits the pin  $m'$ , formed upon the front surface of the counterbalancing-plate F, so that by this pin and orifice the said counterbalancing-plate F and yoke M are locked together. The counterbalancing-plate F has the central slot,  $o$ , formed in it, through which the shaft C passes, and which permits the plate to have its irregular movement.

Upon the rear surface of the counterbalancing-plate F are formed, just beyond the ends of the slot  $o$  and in line with the said slot, the blocks  $p p$ , which enter and fit nicely in the slots  $q q$ , made in the cross-piece N, riveted fast to the hub  $r$  of the fly-wheel O, which is made fast to the shaft C, so that as the shaft is revolved the fly-wheel and cross-piece N will be revolved with it. The latter being connected to the counterbalancing-plate F by the blocks  $p p$ , entering slots  $q q$  in the cross-piece, the counterbalancing-plate F will be revolved, and this plate being connected to the yoke M by pin  $m'$ ,

entering orifice  $m$  in the yoke, the yoke will be revolved, and its revolution being upon and around the eccentric  $l$ , it will receive a positive irregular movement from the eccentric, which will be imparted through pin  $m$  to the plate F, the slot  $o$  in the plate and the slots  $q q$  in the cross-piece N permitting such irregular movement. The eccentrics  $l$  and  $B^2$  being opposite to the eccentrics  $B'$  and  $g$ , which impart irregular motion to the plate K, it follows that the irregular movement of the counterbalancing-plate F will be exactly the opposite of the irregular movement of the face-plate K, and that the plate F will thus offset the tendency of the plate K to cause a lurching or swaying movement of the machine. The chuck D is composed of the head  $d'$  and arms  $d^2 d^3$ , pivoted to the said head. The head  $d'$  is formed with the above-mentioned screw-shank  $k$ , by which the chuck is attached to the plate K, and beneath the pivots of the arms  $d^2 d^3$  the head  $d'$  is recessed, as shown at  $s s$ , Fig. 3, and in these recesses are placed the coiled springs  $t$ , which act upon the arms  $d^2 d^3$  in front of their pivots, so as to tend to force their outer ends outward or away from each other. The arms  $d^2$  are each provided at their outer ends with a pivoted plate,  $u$ , pressed inward at its rear end by the spring  $u'$ , and at their rear ends with the pivoted plates  $v$ , which are adapted to rest upon the outer edge of the cam P. The arm  $d^3$  has pivoted to its outer end the plate  $u^2$ , which is formed with the fin  $u^3$  and acted upon by the springs  $u'$ , and provided at its inner end with the pivoted plate  $u^4$ , which, like the plate  $v$ , rests upon the cam P. The cam P is held upon the collar  $j$  of the face-plate K by means of the set-screw  $j'$ , entering the groove  $j^2$ , made in the said collar, as shown in Fig. 2, so that by loosening the said set-screw the cam may be turned upon the collar  $j$  as an axis. The block E is formed with the openings  $E'$ , as shown in Fig. 2, to receive the forward ends of the arms  $d^2 d^3$  and plates  $u u^2$ , attached to them, and the block is formed with a groove to receive the fin  $u^3$  of the plate  $u^2$ , so that the block may always be placed in the chuck in the proper position. The block E being placed upon the arms  $d^2 d^3$ , a wrench will be applied to the set-screw  $j'$  to loosen the cam P on collar  $j$ ; then the cam will be turned in the direction indicated by the arrow in Fig. 3, which will force the rear ends of the arms  $d^2 d^3$  outward, causing the forward ends of the arms and plates  $u u^2$  thereof to grasp and firmly hold the block E. The set-screw  $j'$  will then be turned inward for holding the cam P in place. The opposite movement of the cam P upon the collar  $j$  will cause the arms  $d^2 d^3$  to release the block E. The plates  $v$  and  $u^4$  being pivoted to the arms  $d^2 d^3$  serve to always effect a true bearing of the said arms upon the edge of the cam P, and the said plates  $u$  and  $u^2$ , being pivoted, accommodate themselves to the recesses in the block, and also to the

inclined position which the arms  $d^2$   $d^3$  assume while holding the block, so that a firm and true grasp of the block will always be effected.

When the machine is to be used for pounding hat-bodies, the block E, which is oval and elliptical in form, will be placed in the chuck D, as shown in Fig. 2, and the collar B will be turned in the opening  $b$  by a rod entering slot  $c$  and recess  $c'$ , so that recess  $c'$  will stand above the shaft C, and held by the set-screw  $c^2$ , which will shift the eccentric B', bring the still-point nearly over the shaft C, where the attendant can apply the sand-paper to the hat-body with the greatest ease.

When the machine is to be used for turning, the collar B will be turned in the opening  $b$  so that the recess  $c'$  will stand to one side of the shaft C, which will again shift the eccentric B', and bring the still-point, nearly in the same horizontal plane with the shaft C, where it is most convenient to apply the cutting-tool.

In turning the collar B it will be seen that both eccentrics B' B<sup>2</sup> will be shifted in opposite directions, so that whatever change is thereby given to the irregular movement of the yoke H and plate K and the parts attached thereto a like opposite change will be given by the movement of the eccentric B<sup>2</sup> to the yoke M and counterbalancing-plate F, so that the plate F will always perfectly counterbalance the machine, so that the parts cannot possibly get out of balance.

Having thus fully described our invention, we claim as new and desire to secure by Letters Patent—

1. The plate K, arranged to receive irregular rotary movement from the eccentric B', in combination with the counterbalancing-plate F, arranged to receive opposite irregular movement from the eccentric B<sup>2</sup>, the eccentrics B' B<sup>2</sup> being adapted to be turned for shifting the still-point, substantially as and for the purposes described.

2. The collar B, formed with the opposite eccentrics B' B<sup>2</sup>, and adapted to be turned in the openings  $b$  of the upright  $a^2$  of the frame, substantially as and for the purpose described.

3. The collar B, formed with the eccentrics B' B<sup>2</sup>, in combination with means, substantially as described, for imparting irregular motion to the face-plate K and counterbalancing-plate F, as and for the purposes set forth.

4. The collar B, formed with the eccentrics B' B<sup>2</sup>, the plate G, formed with eccentric  $g$ , placed on eccentric B', yoke H, placed on eccentric  $g$ , slotted plate I, secured to shaft C, and face-plate K, connected to yoke H and formed with blocks that move in the slots made in the plate I, in combination with the plate L, formed with eccentric  $l$ , placed on eccentric B<sup>2</sup>, yoke M, counterbalancing-plate F, attached to yoke M, and slotted cross-piece N, in the slots of which the blocks  $p$  of the plate F move, the cross-piece being arranged to revolve with the shaft C, substantially as and for the purposes described.

5. The face-plate K, formed with the collar  $j$ , in combination with the cam P, placed thereon, and the chuck D, provided with the pivoted arms  $d^2$   $d^3$ , the arms being provided at their ends with pivoted plates, substantially as and for the purposes described.

6. The chuck D, composed of head  $d'$ , pivoted arms  $d^2$   $d^3$ , provided at their ends with pivoted plates, the plate  $w^2$  being formed with the fin  $w^3$ , in combination with the plate K, having collar  $j$ , and cam P, adapted to be revolved upon the said collar for operating the arms  $d^2$   $d^3$ , substantially as and for the purposes set forth.

WILLET THOMPSON.  
JOSEPH A. GEORGE.

Witnesses:

WILLIAM H. MOUNTAIN,  
JOHN J. KELLER.